

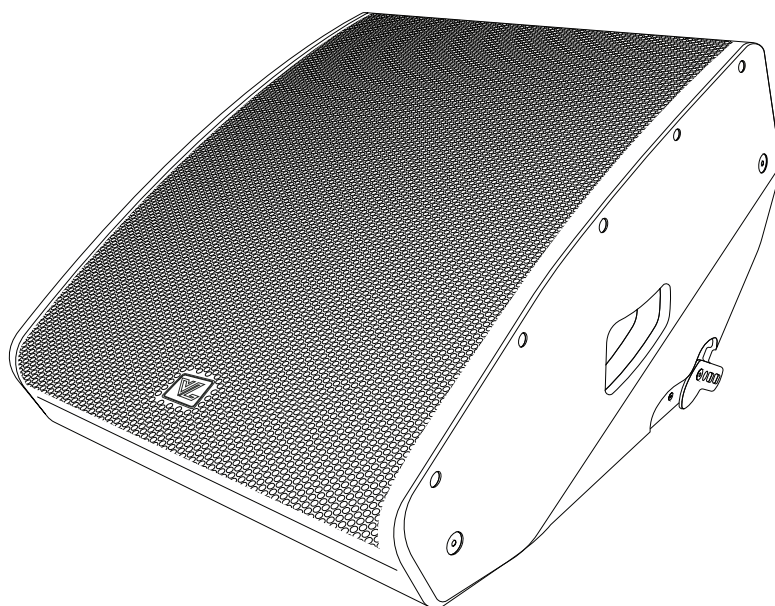

# VEDA SERIES II - 12M

2-WAY STAGE MONITOR SPEAKER



**USER MANAUL**

[WWW.VL.CO.TH](http://WWW.VL.CO.TH)

# INTRODUCTION

## DESCRIPTIONS

The Veda Series II - 12M from VL Audio is a passive stage stage monitor designed to deliver a highly versatile solution, from fixed installations to the popular portable PA applications. Its rotatable horn with 90° x 60° dispersion means the enclosure can also be used as a PA system.

## FEATURE

- 98dB Sensitivity, 134dB maximum SPL
- System rating : 400W Continuous, 1600W Peak
- Designed to work with Veda Series II system



## DIMENSIONS

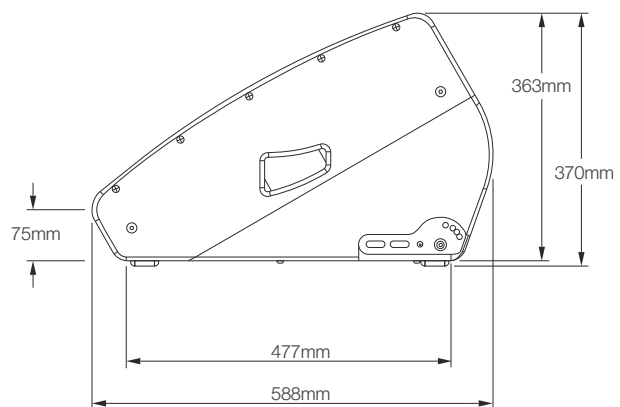
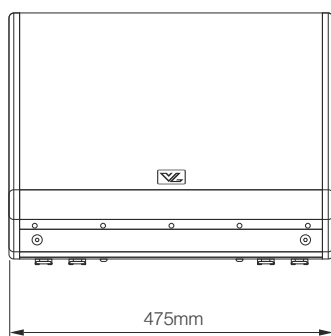
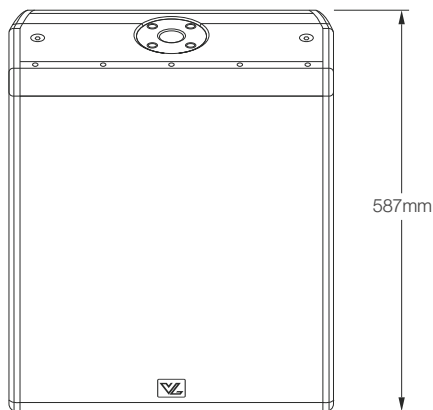

## APPLICATIONS



STAGE MONITOR

STEREO SYSTEM WITH CENTER MONO SUB

# TECHNICAL SPECIFICATIONS

## SPECIFICATIONS

FREQUENCY RESPONSE (-3dB)	58Hz - 16kHz
FREQUENCY RANGE (-6dB)	48Hz - 18.5 kHz
MAX. CALCULATED SPL	134dB
NOMINAL DIRECTIVITY	HORIZONTAL 90°, VERTICAL 60°
CROSSOVER POINT	1.5kHz

## TRANSDUCER

LF TRANSDUCER	1.7" (ND44)
LF SENSITIVITY @ 1w/1m	97dB
LF NOMINAL IMPEDANCE	8Ω
LF POWER HANDLING	400W (CONTINUOUS), 1600 (PEAK)
HF TRANSDUCER	12", 3" V.C. (12FW76)
HF SENSITIVITY @ 1w/1m	106dB
HF NOMINAL IMPEDANCE	8Ω
HF POWER HANDLING	100W (CONTINUOUS), 400 (PEAK)

## INPUT/OUTPUT SECTION

INPUT CONNECTOR	NEUTRIK NL4MP
OUTPUT CONNECTOR	NEUTRIK NL4MP

## PHYSICAL SPECIFICATIONS

CABINET/CASE MATERIAL	15mm. PLYWOOD WITH WATER BASED TEXTURED COATINGS
HANDLES	2 HANDLE
POLE MOUNT/CAP	YES
GRILLE	STEEL 1.4mm
COLOR	BLACK

## SIZE

HEIGHT	370mm
WIDTH	475mm
DEPTH	588mm
WEIGHT	30kg

## SHIPPING INFORMATIONS

PACKAGE HEIGHT	440mm
PACKAGE WIDTH	540mm
PACKAGE DEPTH	650mm
PACKAGE WEIGHT	30kg